



# ICI

---

INFRARED CAMERAS INC

## SOUND DETECT FM QUICK START GUIDE

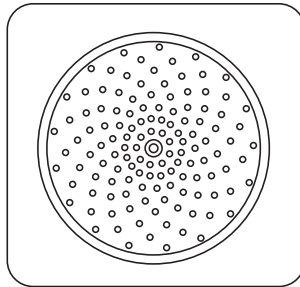

ICI cameras fall under US Federal Law and Export Control.

2105 W. Cardinal Dr. Beaumont, TX 77705  
Phone: (409) 861-0788  
Toll Free: (866) 861-0788  
[infraredcameras.com](http://infraredcameras.com)  
[support@infraredcameras.com](mailto:support@infraredcameras.com)  
We Are IR™

©Copyright 2024, Infrared Cameras, Inc. - All rights reserved. The contents of this document may not be reproduced in whole or in parts without the written consent of the copyright owner.

Printed in the United States of America.

2105 W. Cardinal Dr.  
Beaumont, TX 77705  
(866) 861-0788  
[www.infraredcameras.com](http://www.infraredcameras.com)

Revision: 06.2024-001

THE MANUFACTURER RESERVES THE RIGHT TO ALTER THE SPECIFICATIONS OF THE PRODUCT WITHOUT PRIOR NOTIFICATION. THE MANUFACTURER ALLOWS HIMSELF THE RIGHT TO MODIFY WITHOUT ANY PRELIMINARY OPINION THE TECHNICAL SPECIFICATIONS OF THE PRODUCT. THIS MANUAL MAY CONTAIN TECHNICAL INACCURACIES OR TYPOGRAPHICAL ERRORS.

NOTICE ALL STATEMENTS, INFORMATION, AND RECOMMENDATIONS IN THIS MANUAL ARE BELIEVED TO BE ACCURATE BUT ARE PRESENTED WITHOUT WARRANTY OF ANY KIND. NOTWITHSTANDING ANY OTHER WARRANTY HEREIN, ALL DOCUMENT FILES AND SOFTWARE ARE PROVIDED "AS IS" WITH ALL FAULTS. ICI DISCLAIMS ALL WARRANTIES, EXPRESSED OR IMPLIED, INCLUDING, WITHOUT LIMITATION, THOSE OF MERCHANTABILITY, FITNESS FOR A PARTICULAR PURPOSE AND NONINFRINGEMENT OR ARISING FROM A COURSE OF DEALING, USAGE, OR TRADE PRACTICE.

THE SOFTWARE LICENSE AND LIMITED WARRANTY FOR THE ACCOMPANYING PRODUCT ARE SET FORTH IN THE INFORMATION PACKET THAT SHIPPED WITH THE PRODUCT AND ARE INCORPORATED HEREIN BY THIS REFERENCE. IF YOU ARE UNABLE TO LOCATE THE SOFTWARE LICENSE OR LIMITED WARRANTY, CONTACT YOUR ICI REPRESENTATIVE FOR A COPY.

IN NO EVENT SHALL ICI BE LIABLE FOR ANY INDIRECT, SPECIAL, CONSEQUENTIAL, OR INCIDENTAL DAMAGES, INCLUDING, WITHOUT LIMITATION, LOST PROFITS OR LOSS OR DAMAGE TO DATA ARISING OUT OF THE USE OR INABILITY TO USE THIS MANUAL, EVEN IF ICI HAS BEEN ADVISED OF THE POSSIBILITY OF SUCH DAMAGES.

## Package Includes

---

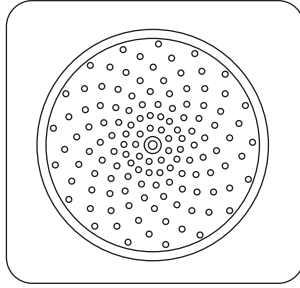

Sound Detect FM device

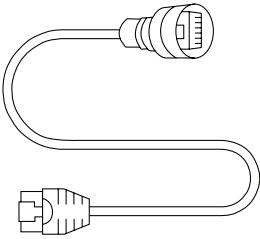

Ethernet Cable

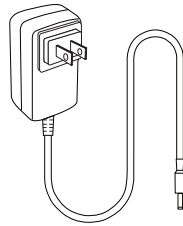

Power Adapter

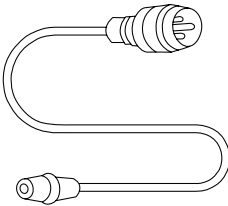

Coaxial Cable

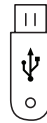

Software USB Drive

**ENSURE ALL SYSTEM EQUIPMENT AND COMPONENT ITEMS ARE PRESENT BEFORE CONTINUING.**

## Tools

---

- Electric drill
- Expansion bolts
- Securing cables or straps

**ON PERSONAL INSTALLS, THE COMPANY PROVIDES ALL THE TOOLS AND EQUIPMENT REQUIRED TO SUCCESSFULLY COMPLETE THE INSTALLATION.**

**PROFESSIONAL INSTALLATION IS RECOMMENDED.**

**MOUNTING GUIDES VARY BY BRACKET. DO NOT DRILL HOLES BEFORE RECEIVING THE PACKAGE.**

## PPE Requirements

---

- Safety glasses
- Working gloves (recommended)
- Comply with all site PPE requirements

**ENSURE THE INSTALLATION COMPLIES WITH SITE SAFETY AND PPE REQUIREMENTS. SAFETY GLASSES SHOULD BE WORN AT ALL TIMES. GLOVES ARE HIGHLY RECOMMENDED.**

## Set Up: Fixed Wall Installation

---

**A.**

Mark the fixing holes for the mounting bracket; then, mount the mounting bracket using expansion bolts.

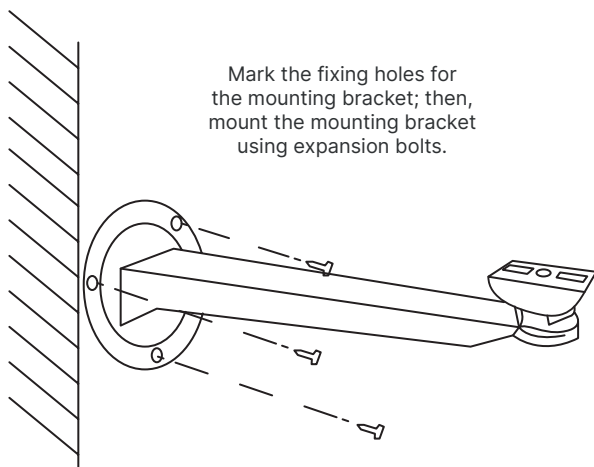

**B.**

Mount the Sound Detect FM to the mounting bracket using standard mounting screws.

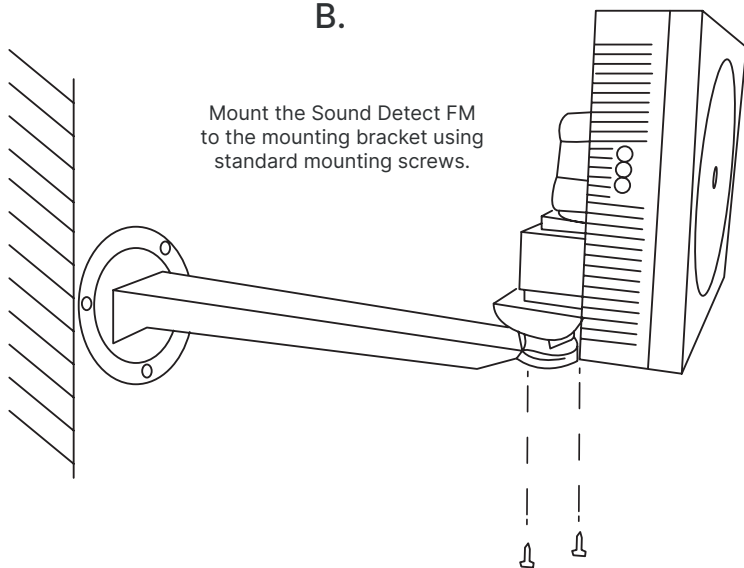

### C.

Remove the caps from the ports.

### D.

Insert the Ethernet cable into the left port and rotate the locking mechanism to the right to secure the cable.

### E.

Insert the Power cable into the right port and rotate the locking mechanism to the right to secure the cable.

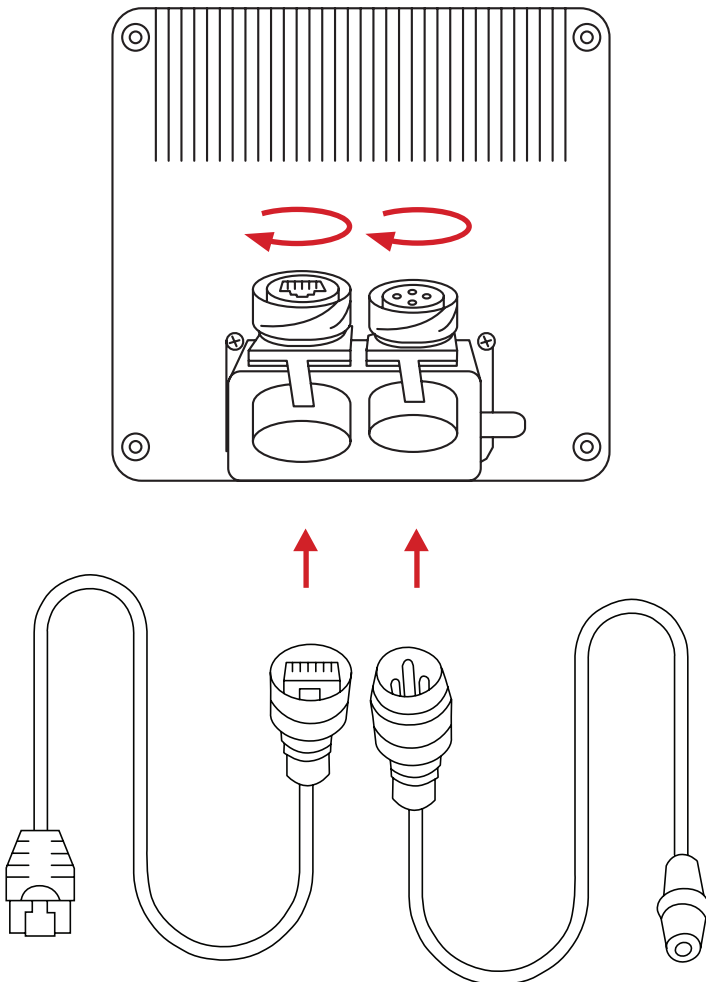

## F.

Follow the basic system map to finish connecting the system.

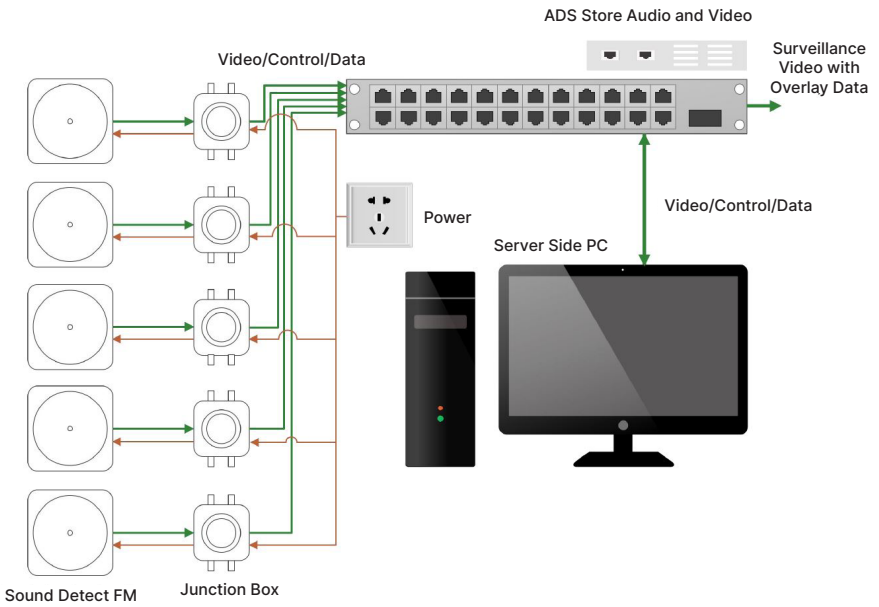

## Set Up: Fixed Column Installation

---

**A.**

Affix the mounting bracket using secure cables or straps.

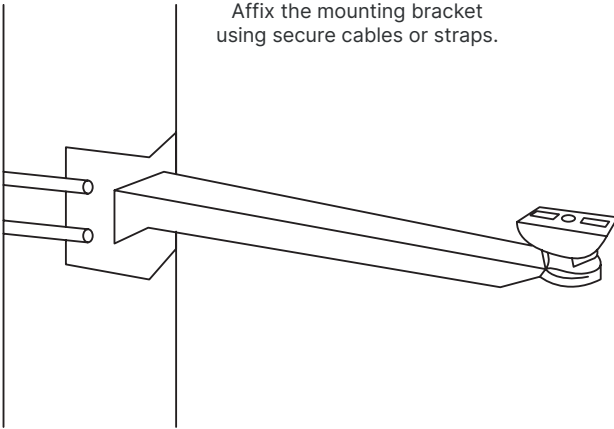

**B.**

Mount the Sound Detect FM to the mounting bracket using standard mounting screws.

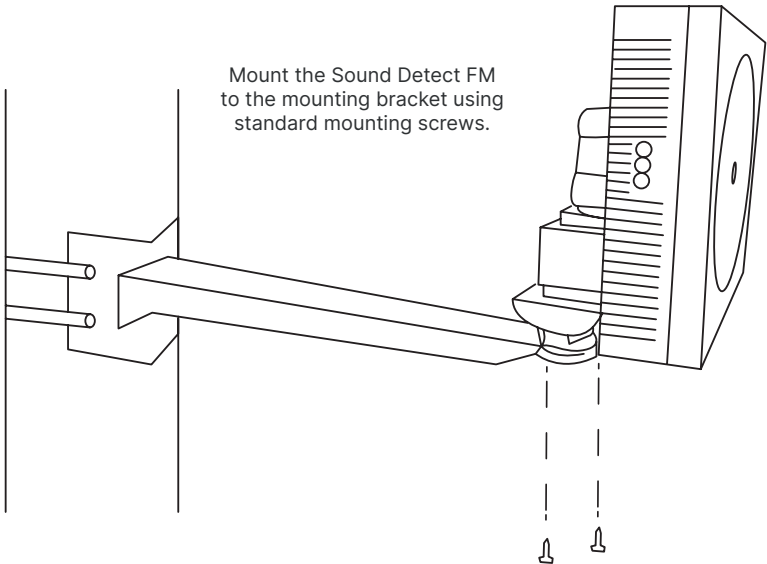



## C.

Remove the caps from the ports.

## D.

Insert the Ethernet cable into the left port and rotate the locking mechanism to the right to secure the cable.

## E.

Insert the Power cable into the right port and rotate the locking mechanism to the right to secure the cable.

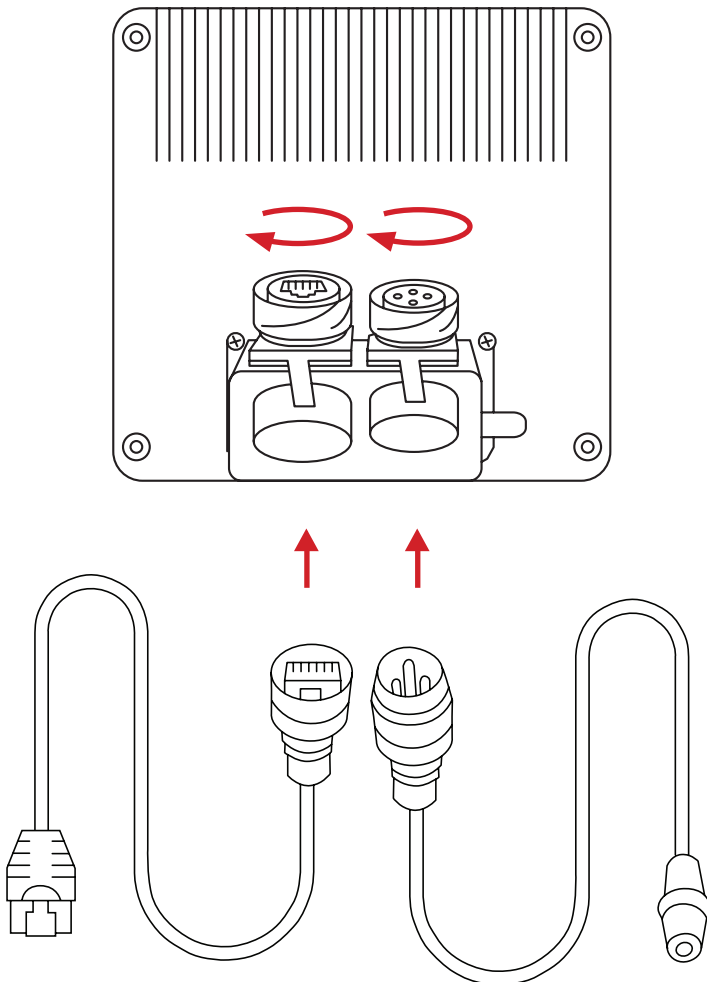

## F.

Follow the basic system map to finish connecting the system.

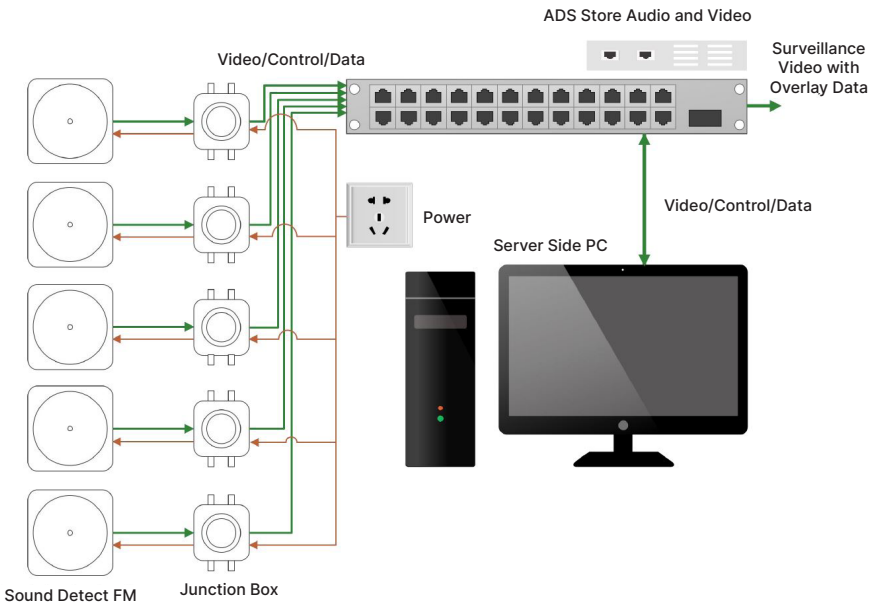

## Set Up: Hanging Fixed Installation

---

**A.**

Mark the fixing holes for the mounting bracket on the ceiling; then, mount the mounting bracket using expansion bolts.

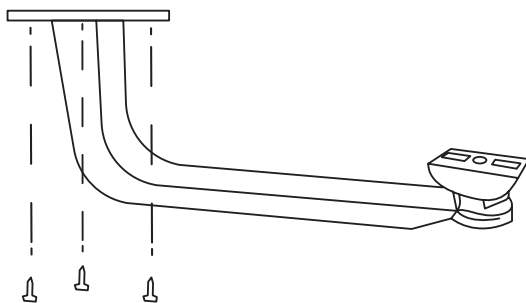

**B.**

Mount the Sound Detect FM to the mounting bracket using standard mounting screws.

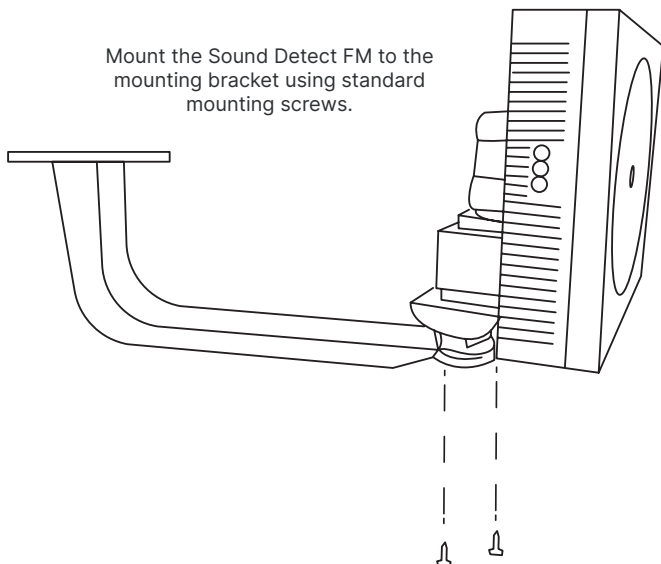

## C.

Remove the caps from the ports.

## D.

Insert the Ethernet cable into the left port and rotate the locking mechanism to the right to secure the cable.

## E.

Insert the Power cable into the right port and rotate the locking mechanism to the right to secure the cable.

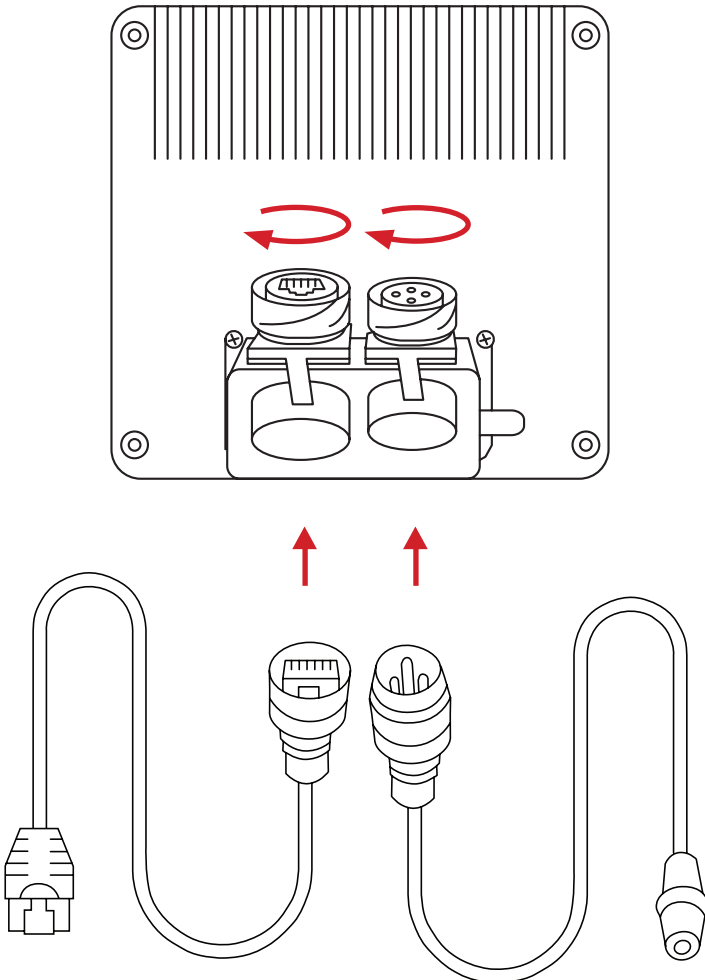

## F.

Follow the basic system map to finish connecting the system.

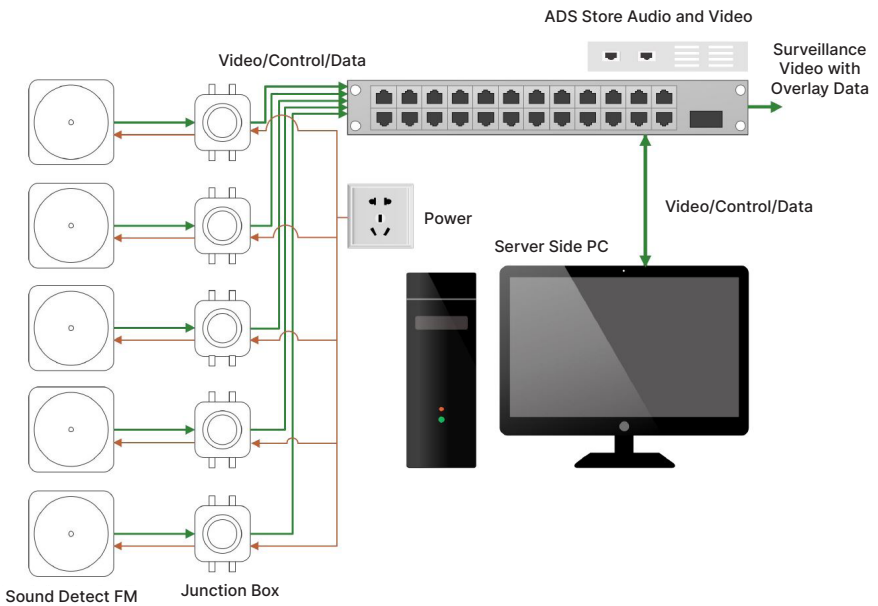

# Software

---

Software arrives installed on computers and tablets purchased from ICI as complete systems and it will launch automatically on startup. A copy of the software is provided on the Software USB Drive. Documentation can be found online on the IR Flash Pro web page under the Downloads section or at this address:

<https://infraredcameras.com/ir-flash-pro-manual/>

## Recommended System Requirements

- **Processor:** i5 Quad Core or above
- **RAM:** 4 GB or above
- **OS:** Windows 8/8.1/10
- **Hard Drive:** 256 GB or above
- **Resolution:** 1920 x 1080

Use the following steps if installing IR Flash Pro on a user computer:

**A.**

Install IR Flash software using the software USB drive. Refer to the IR Flash User Manual for instructions.

**B.**

Once installed, launch IR Flash software by double-clicking the associated desktop icon.

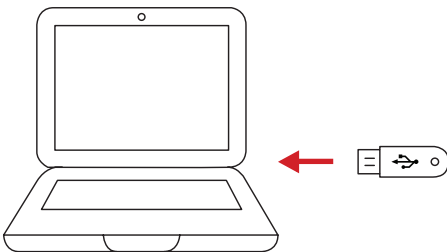

## About ICI / Contact

---

Infrared Cameras, Inc.  
2105 W. Cardinal Dr.  
Beaumont, TX 77705

Phone: (409) 861-0788 | Toll Free: (866) 861-0788 | International: (409) 861-0788

General Inquiry: [support@infraredcameras.com](mailto:support@infraredcameras.com)

Website: [www.infraredcameras.com](http://www.infraredcameras.com)

You may reach a representative by phone or email Mon – Fri 8:00AM – 5:00PM CST.

ICI manufactures complete systems and software. We can provide complete engineering, software, and OEM solutions. Our Fortune 500 clients rely on us for infrared equipment and thermography training (which we offer through the Infrared Training Institute).

In addition to providing custom germanium, silica, and sapphire optics, we also build windows for enclosures, as well as custom pan and tilt units. We can even provide customizable explosion-proof systems.

Our knowledge and experience stems from years of using infrared imaging and temperature measurement instruments to provide solutions to: managers, engineers, scientists, inspectors and operators in space, power companies, medical, pulp and paper, food industry, research and development, and various process industries. You can see our products and services used in industrial, commercial, and government applications worldwide. Originally named Texas Infrared (still DBA), Infrared Cameras, Inc. has been in business since March, 1995.

Thank you for your dedicated and continued support.